

More ways to learn about  
Shandong FUJIZY elevator



Official Tiktok



Official wechat  
public account



360° Company  
panorama

 SHANDONG FUJIZY ELEVATOR CO., LTD.

FREIGHT  
ELEVATOR

 **FUJIZY**

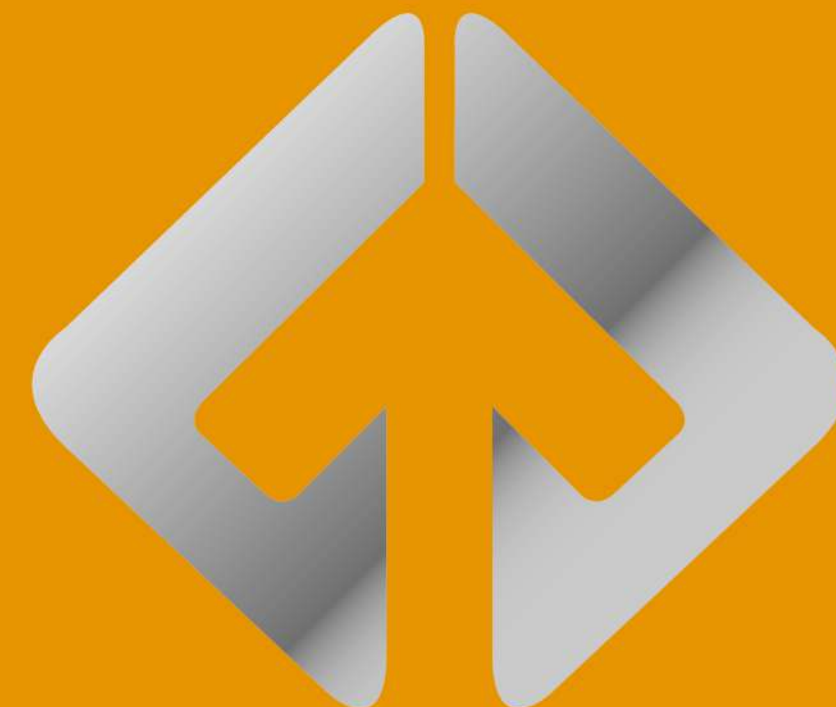

SHANDONG FUJIZY ELEVATOR CO., LTD



# Large load freight elevator If you do, all things can ascend

Integrated with advanced drive and control systems, it is safe, stable, and has superior performance. It is specially designed for large tonnage freight transportation, with a large carrying capacity and sturdy structure, capable of carrying up to 20 tons. There are comprehensive solutions for different application scenarios.

Mature and reliable technology  
Load capacity can reach

**20T**

Larger door opening size

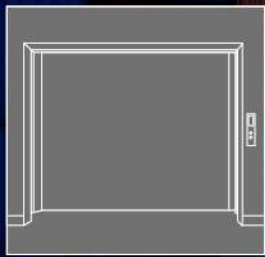

Wide speed range,  
Up to

**2.5M/S**



## High sensitivity load detection

High sensitivity load detection ensures safe carrying during each operation.



## Extra large load capacity

Specially designed for heavy-duty freight transportation, equipped with advanced drive and control systems, capable of designing a maximum load capacity of 20 tons.



## Extra large space

The more compact shaft structure allows the elevator car to have more space and accommodate more goods; A larger door opening size facilitates the entry and exit of large goods.



## Ultra high strength

The overall structure is made of high-strength steel, and the main load-bearing components have been strengthened. The car walls and floors are made of durable and wear-resistant steel plates, which are not easily deformed or worn.

# Car decoration



## FJ-HJX-001

Standard car

- Ceiling  
Spray painted steel plate (color optional)
- Car Wall  
Spray painted steel plate (color optional)
- Car Door  
Spray painted steel plate (color optional)
- Lighting  
Energy saving fluorescent lamp
- Floor  
Patterned steel plate

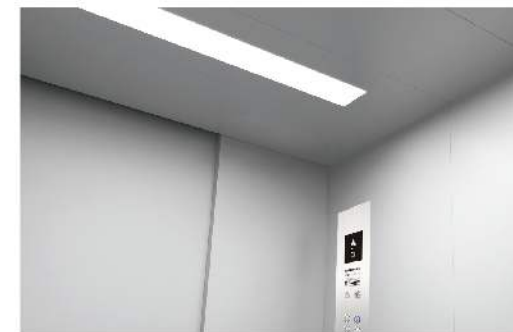
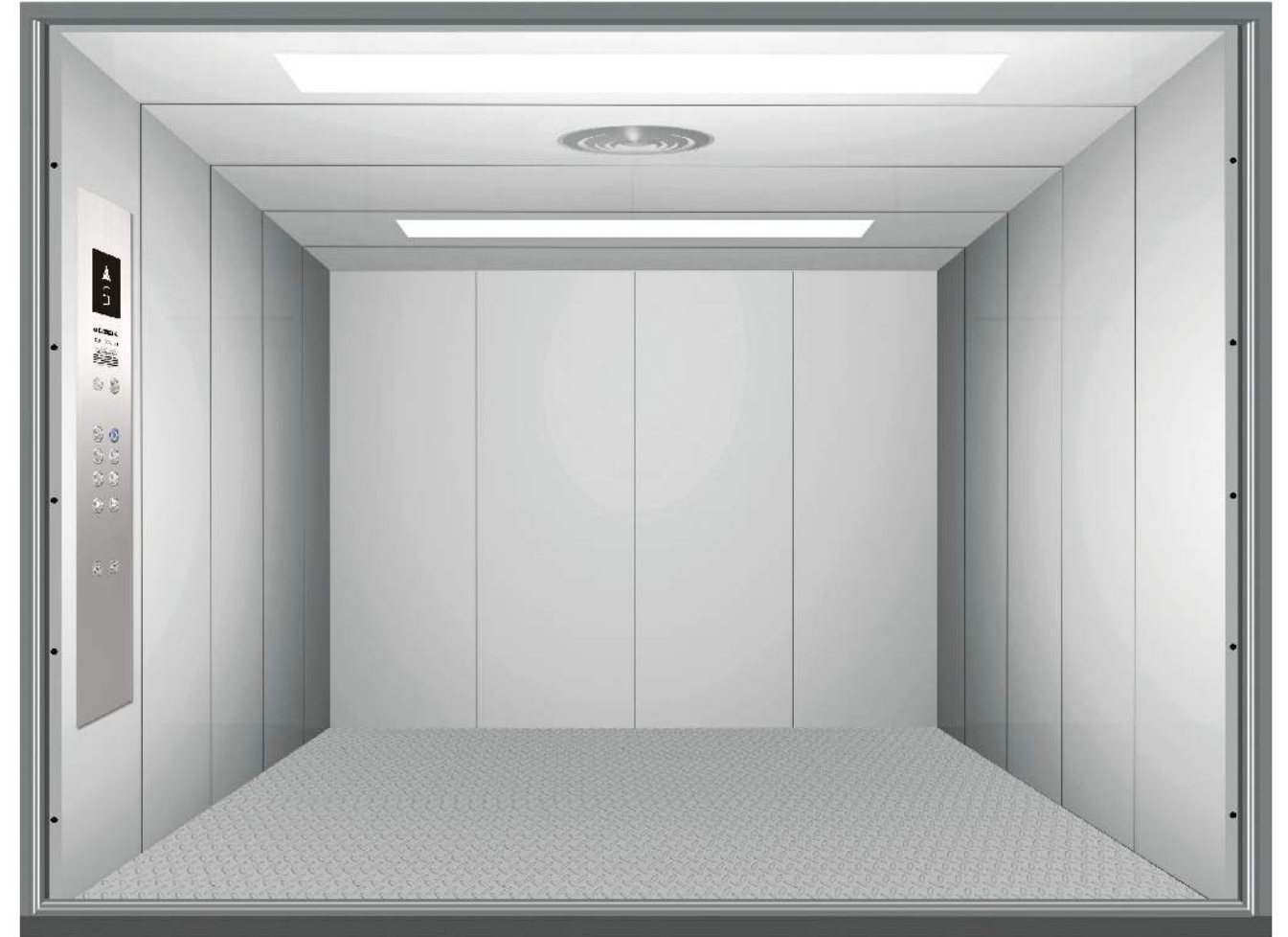

## FJ-HJX-002

Optional car

**Electrophoretic patterned steel flooring**  
Anti slip and corrosion-resistant

- Ceiling  
Stainless hair pattern
- Car Wall  
Stainless hair pattern
- Car Door  
Stainless hair pattern
- Lighting  
Energy saving fluorescent lamp
- Floor  
Patterned steel plate

## COP/HOP



**FJ-CZ-022**  
Standard

Hairline stainless steel panel

The streamlined shape is novel and unique, with a strong sense of modernity; The display designed according to ergonomics is easy and comfortable to operate.



**FJ-WH-001**  
Standard

Hairline stainless steel panel

## Ceiling series



**FJ-DD-014**  
Standard

Spray coated steel plate



**FJ-DD-015**  
Optional

Hairline stainless steel

## Landing door series



**FJ-CM-002**

The doors and door covers of the other floors are coated with steel plates(Standard optional RAL1013 wrinkle, RAL1014 wrinkle, RAL7042 sand grain)

Note: The image is computer-generated and may differ slightly from reality.



**FJ-CM-002**  
Color options

# Function table

## Standard function

Complete selection control	During the operation of the elevator, it automatically responds to the up and down call button signals while responding to the command signals inside the car. Passengers on any floor can call the elevator by registering the up and down call signals.
Maintenance operation	When entering maintenance mode, the elevator runs at a slow jog.
Direct docking	The elevator decelerates completely according to the principle of distance, and there is no crawling during leveling.
Slow self rescue operation	When the elevator is in a non maintenance state and has not stopped in the leveling area, as long as it meets the safety requirements for starting, the elevator will automatically run at a slow speed to the leveling area and open the door to release people.
Emergency rescue operation	Set up an emergency electric operation switch to replace the manual turning device.
Elevator locking service	There is a lock elevator switch installed on the call box of the base station. After the switch is activated, the elevator only responds to commands inside the car. After that, run until the base station closes the door and stops the elevator after about 10 seconds.
Self returning base station	When there is no operating command for a period of time, the elevator will automatically return to the base station to wait for the elevator.
Lighting inside the elevator during waiting Fan automatic power-off	If there are no instructions or external call registration for more than 5 minutes in the elevator, the lighting and fans inside the car will automatically shut off. But after receiving instructions or summoning signals, it will automatically power on and put into use.
Service floor setting	The system can flexibly choose to close or activate one or more elevator service floors and stopping floors as needed.
Automatic correction of floor position signals	When the system is running, the position signal of the elevator is corrected based on the position data obtained from self-learning at each terminal switch action point and each floor level switch action point.
Dot matrix floor display	Dot matrix floor displays are installed inside and outside the elevator car to instantly display the elevator's operating status.
Special floor display	Floor display characters can be freely set for special on-site requirements.
Reverse automatic cancellation	When the elevator reaches the terminal level or changes direction, all previously registered reverse instructions will be automatically cancelled.
Door opening and closing fault protection	When it is detected that the door has not been effectively closed after exceeding the set number of times, the system stops opening and closing the door and outputs a fault.
Upward overspeed protection	When the upward speed of the elevator exceeds the set value, the rope clamp will activate, causing the elevator to stop running.
Downward overspeed protection	When the downward speed of the elevator exceeds the set value, the speed limiter and safety gear will activate, causing the elevator to stop running.
Open door button to open the door	When the elevator stops in the door area, you can press the door opening button in the car to reopen the doors that have already been closed or have not yet been closed.
Close the door button in advance	When keeping the door open, you can press the close button to immediately respond to the closing action and close the door in advance.
Repeatedly open the door	If the elevator continues to close for 15 seconds without closing the door lock, the elevator will switch to the open state.
Full load bypass	When the car is fully loaded, the elevator does not respond to call signals passing by but only responds to command signals.
Overload protection	When the elevator load exceeds the set value, the elevator beeps to indicate overload and does not operate when opening the door.
Emergency fire return operation	After the fire switch is activated, the elevator travels straight to the fire escape, opens the door to release people, and then stops the elevator.

## Standard function

Reverse operation protection	When the actual direction of elevator operation is inconsistent with the instruction direction, it will immediately stop urgently and trigger a fault alarm.
Anti slip protection	The elevator has been running continuously for the time specified by the limiter, but the leveling switch has not been activated, so all operations of the car have been stopped.
Fault self-diagnosis	The controller can record the latest 11 faults for quick troubleshooting and restoration of elevator operation.
Alarm bell	In case of emergency, press the alarm button inside the elevator car, and the alarm on the top of the elevator car will sound.
Emergency lighting	When there is a power outage, the emergency lighting inside the elevator car will automatically turn on.
Five party communication device	Through the intercom, the car, roof, machine room, pit, and duty room can communicate with each other.
Door light curtain protection	When there is something blocking between the two doors, the door area light curtain device will activate to open the elevator door.
Anti terminal overtravel protection	The upper and lower terminals of the elevator are equipped with terminal deceleration switches and terminal limit switches to ensure that the elevator will not exceed its travel distance.
Deceleration switch fault protection	In the event of a deceleration switch failure, the elevator will come to an emergency stop to prevent tipping or squatting.
Safety circuit fault protection	When the system receives a safety circuit fault signal, it immediately stops and prevents the elevator from running in the event of a fault.
Car accidental movement protection	The elevator should have protective devices to prevent or stop the accidental movement of the elevator car away from the landing station when the landing door is not locked and the car door is not closed.
Pre torque setting	The system can output torque that matches the corresponding load in advance to ensure the comfort of the elevator.
Driver operated operation	After the driver control switch is installed in the elevator car, it can only be operated by the driver inside the car.
Door opening hold function	There is a door hold button installed on the control panel, which can extend the door opening time after action.

## Optional function

Power outage emergency leveling	When the normal power supply is cut off, the rechargeable battery provides power to the elevator, and the elevator travels to the nearest floor station.
Firefighter operation	When the firefighter switch is activated, the elevator runs until the base station opens the door and releases people, exclusively for firefighters to operate.
Auxiliary operation panel operation	In addition to the main control panel, a secondary control panel can be optionally installed for the convenience of passengers.
Front and rear door operation	The elevator can have both front and rear doors, which can be controlled separately for safety and convenience.
Open door button to open the door	Two elevators share external call signals and automatically dispatch call responses to improve operational efficiency.
Linkage operation	Multiple elevators (3-8) share external call signals, automatically dispatch call responses, and improve operational efficiency.
Weighing signal compensation	The system can use weighing signals in high-end applications to compensate for elevator start-up.
Car camera function	Installing cameras in the elevator car can monitor the situation inside the car.

# Small machine room freight elevator construction parameters

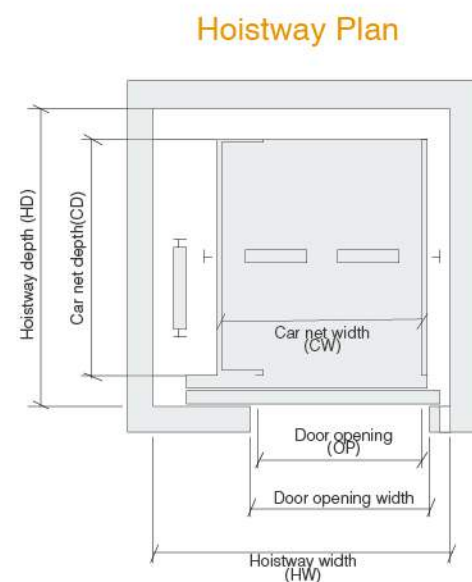
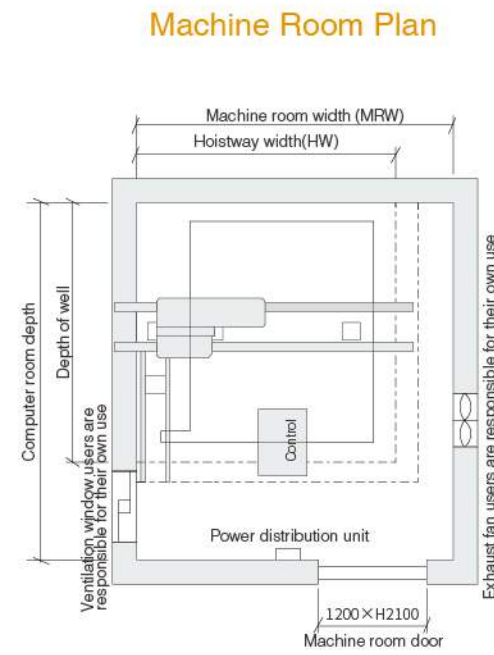
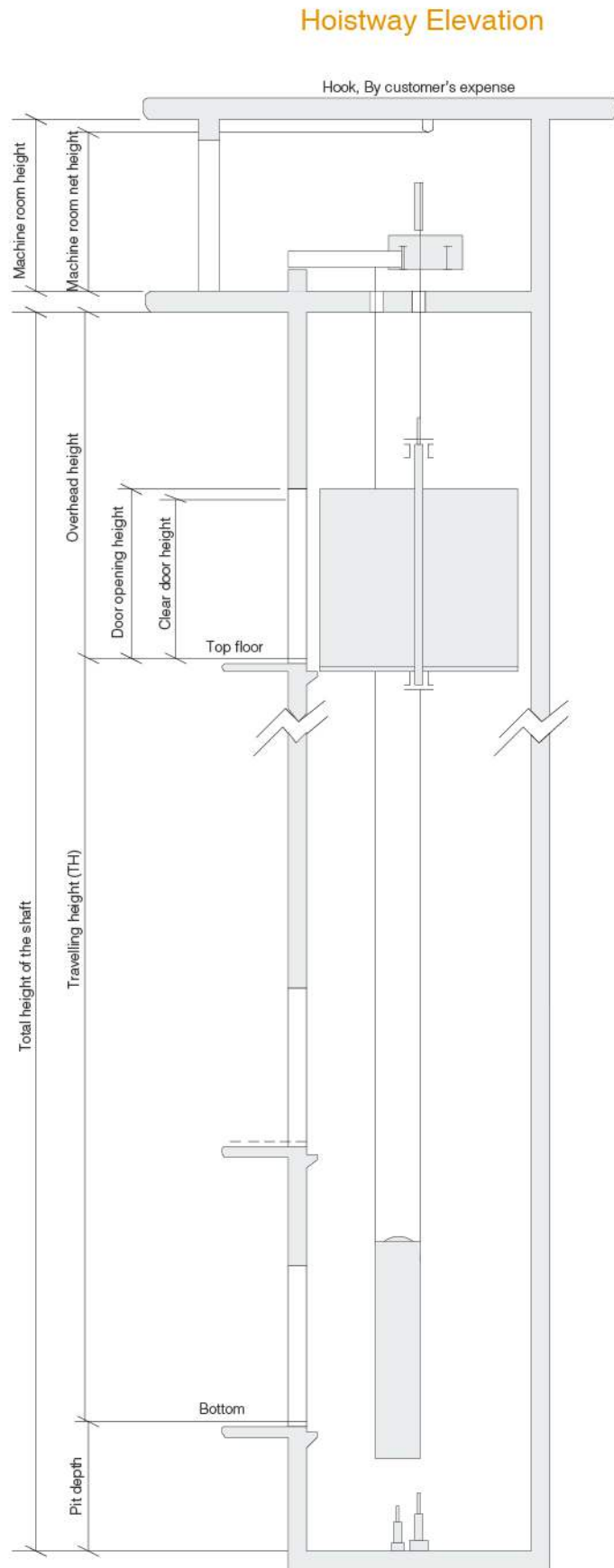

Is there a computer room available (Relative position)	Type of shaft	Load (kg)	Speed (m/s)	Cabin size (W*D*H) (mm)	Door opening size (W*H) (mm)	Shaft size (W*D) (mm)	Machine room height (mm)	Overhead height (mm)	Pit (mm)	Is it connected	Structure type
		1000	0.5	1400*1600*2300	1100*2200 Side opening door	2200*2100	2800	4500	1600		2:1 car top wheel, asynchronous motor
		1600	0.5	1400*2400*2300	1300*2200 Side opening door	2400*2900	2800	4600	1700		2:1 car top wheel, asynchronous motor
		1600	0.5	1500*2300*2300	1300*2200 Side opening door	2400*2800	2800	4500	1600		2:1 car top wheel, synchronous motor
		2000	0.5	1800*2300*2300	1500*2200 Side opening door	2650*2800	2800	4500	1600	NO	2:1 car bottom wheel, asynchronous motor
		2000	0.5	1700*2400*2300	1500*2200 Side opening door	2900*2950	2800	4800	1700		4:1 car bottom wheel, synchronous motor
		2000	0.5	1800*2300*2300	1500*2200 Side opening door	2650*2800	2800	4200	1500		2:1 car top wheel, synchronous motor
		2000	1.0	1700*2400*2300	1500*2200 Side opening door	2900*2950	2800	4800	1700		4:1 car bottom wheel, synchronous motor
		2000	0.5	1800*2250*2300	1500*2200 Side opening door	2650*2900	2800	4500	1600		2:1 car top wheel, asynchronous motor
		2000	0.5	1800*2250*2300	1500*2200 Side opening door	2650*2900	2800	4200	1500	YES	2:1 car top wheel, synchronous motor
		2000	0.5	1800*2250*2300	1500*2200 Side opening door	2650*2900	2800	4500	1600		4:1 car top wheel, synchronous motor
		2000	1.0	1700*2400*2300	1500*2200 Side opening door	2900*3050	2800	4800	1700		4:1 car bottom wheel, synchronous motor
		2500	0.5	2000*2500*2300	1600*2200 Side opening door	3000*3000	2800	4600	1600		2:1 car top wheel, asynchronous motor
		2500	1	1700*2500*2300	1500*2200 Side opening door	2650*2950	2800	4800	1700	NO	4:1 car bottom wheel, synchronous motor
		2500	0.5	1700*2500*2200	1500*2200 Side opening door	2650*2800	2800	4800	1700		4:1 car bottom wheel, asynchronous motor
		2500	0.5	2000*2500*2300	1600*2200 Side opening door	2900*2950	2800	4600	1600		2:1 car top wheel, asynchronous motor
		3000	0.5	2200*2600*2300	1800*2200 Side opening door	3400*3050	2800	4800	1700	NO	4:1 car bottom wheel, synchronous motor
		3000	1	2200*2600*2300	1800*2200 Side opening door	3400*3050	2800	4800	1700	NO	4:1 car bottom wheel, synchronous motor
		3000	0.5	2200*2600*2300	1800*2200 Side opening door	3200*3100	2800	4600	1600	NO	2:1 car top wheel, asynchronous motor
		3000	0.5	2200*2600*2300	1800*2200 Side opening door	3650*3250	2800	4600	1600	YES	2:1 car top wheel, asynchronous motor
		3500	0.5	2200*2900*2300	1800*2200 Central opening (four panels)	3700*3400	2800	4800	1800	NO	4:1 car bottom wheel, synchronous motor
		4000	0.5	2100*3400*2300	2000*2200 Central opening (four panels)	3450*3850	2800	4600	1600	NO	4:1 car top wheel, synchronous motor
		4500	0.5	2400*3300*2300	2100*2200 Central opening (four panels)	3700*3750	2800	4600	1600	NO	4:1 car top wheel, synchronous motor
		5000	0.5	2400*3600*2300	2200*2200 Central opening (four panels)	4000*4100	2800	4600	1600	NO	4:1 car top wheel, synchronous motor
		5000	0.5	2400*3600*2300	2200*2200 Central opening (four panels)	3750*4050	2800	4600	1600		4:1 car top wheel, synchronous motor
		8000	0.5	2800*4700*2500	2400*2200 Central opening (four panels)	4400*5200	2800	5100	1600	NO	8:1 car top wheel, synchronous motor
		8000	0.5	2800*4700*2500	2400*2200 Central opening (four panels)	4400*5350	2800	5100	1600	YES	8:1 car top wheel, synchronous motor
		8000	0.25	2800*4700*2500	2400*2200 Central opening (four panels)	4400*5200	2800	5100	1600	NO	8:1 car top wheel, synchronous motor
		8000	0.25	2800*4700*2500	2400*2200 Central opening (four panels)	4400*5350	2800	5100	1600	YES	8:1 car top wheel, synchronous motor
		10000	0.5	3000*5500*2500	2500*2200 Central opening (four panels)	4600*6000	2800	5100	1600	NO	8:1 car top wheel, synchronous motor
		10000	0.5	3000*5400*2500	2500*2200 Central opening (four panels)	4600*6060	2800	5100	1600	YES	8:1 car top wheel, synchronous motor
		10000	0.25	3000*5500*2500	2500*2200 Central opening (four panels)	4600*6000	2800	5100	1600	NO	8:1 car top wheel, synchronous motor
		10000	0.25	3000*5400*2500	2500*2200 Central opening (four panels)	4600*6060	2800	5100	1600	YES	8:1 car top wheel, synchronous motor
		12000	0.5	3100*6400*2500	2600*2200 Central opening (four panels)	4700*6900	2800	5100	1600	NO	8:1 car top wheel, synchronous motor
		12000	0.5	3100*6300*2500	2600*2200 Central opening (four panels)	4700*6960	2800	5100	1600	YES	8:1 car top wheel, synchronous motor
		12000	0.25	3100*6400*2500	2600*2200 Central opening (four panels)	4700*6900	2800	5100	1600	NO	8:1 car top wheel, synchronous motor
		12000	0.25	3100*6300*2500	2600*2200 Central opening (four panels)	4700*6960	2800	5100	1600	YES	8:1 car top wheel, synchronous motor
		20000	0.5	4600*7000*2400	3400*2300 Central opening (four panels)	6500*7700	2800	4500	2500	NO	8:1 car top wheel, synchronous motor

# Machine roomless freight elevator construction parameters

Hoistway Elevation

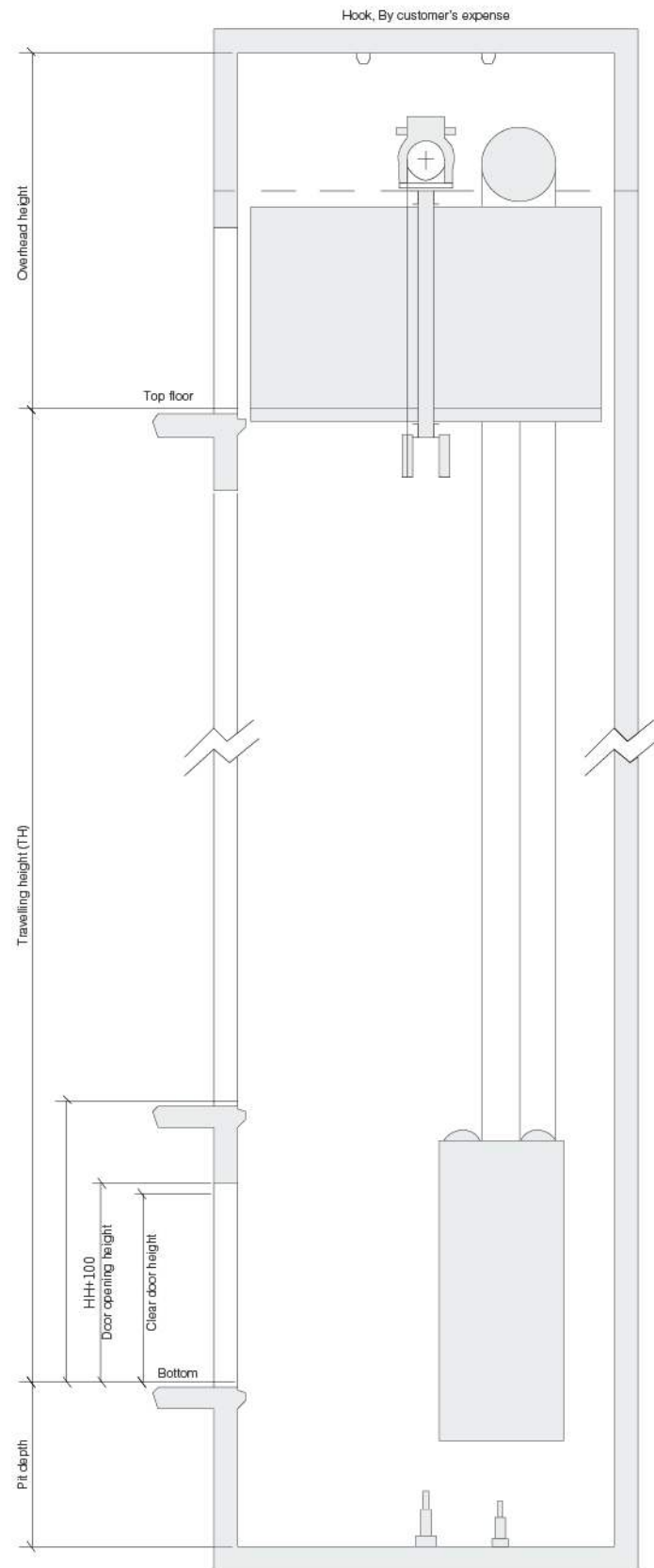

Machine Room Plan

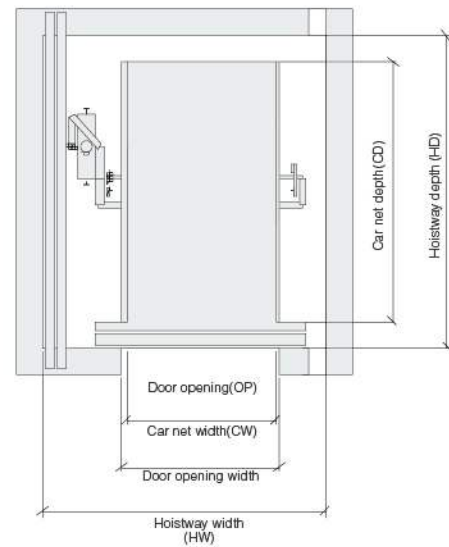

Hoistway Plan

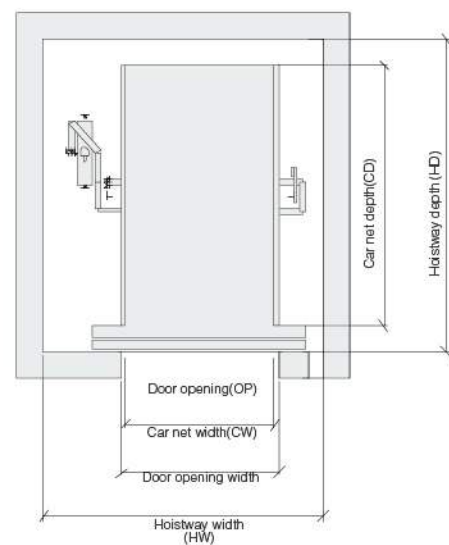

Is there a computer room available (Relative position)	Type of shaft	Load (kg)	Speed (m/s)	Cabin size (W*D*H) (mm)	Door opening size (W*H) (mm)	Shaft size(W*D) (mm)	Machine room height (mm)	Overhead height (mm)	Pit (mm)	Is it connected	Structure type
Machine roomless freight elevator	Concrete	1000	0.5	1400*1600*2300	1100*2200 Side opening door	2300*2200	/	4400	1700	NO	2:1 car top wheel, asynchronous motor
		1600	0.5	1400*2400*2300	1300*2200 Side opening door	2650*2900	/	4800	1800		2:1 car top wheel, synchronous motor
		2000	0.5	1800*2300*2300	1500*2200 Side opening door	2850*2800	/	4600	1600		4:1 car top wheel, synchronous motor
		2000	1.0	1800*2300*2300	1500*2200 Side opening door	2850*2800	/	4600	1600	4:1 car top wheel, synchronous motor	
		2000	0.5	1800*2250*2300	1500*2200 Side opening door	2850*2900	/	4800	1600	YES	4:1 car top wheel, synchronous motor
		2500	0.5	1800*2600*2300	1500*2200 Side opening door	2900*3100	/	4900	1700		4:1 car top wheel, synchronous motor
		3000	0.5	2200*2600*2300	1800*2200 Side opening door	3300*3100	/	4900	1600	NO	4:1 car top wheel, synchronous motor
		3000	1.0	2200*2600*2300	1800*2200 Side opening door	3300*3100	/	4900	1600		4:1 car top wheel, synchronous motor
		3000	0.5	2200*2600*2300	1800*2200 Side opening door	3300*3250	/	5000	1800	YES	4:1 car top wheel, synchronous motor
		3500	0.5	2200*2900*2300	1800*2200 Side opening door	3550*3400	/	4700	1600		4:1 car top wheel, synchronous motor
		4000	0.5	2100*3400*2300	1900*2200 Central opening (four panels)	3550*3900	/	4700	1600	NO	4:1 car top wheel, synchronous motor
		5000	0.5	2400*3600*2300	2200*2200 Central opening (four panels)	3900*4100	/	4700	1600		4:1 car top wheel, synchronous motor

# Car elevator

## Make the car easy up and down



Shandong FUJIZY control automotive elevator fully considers the large volume and load of automotive products, adopts world leading automotive lifting technology to improve elevator configuration and quality assurance, and combines various humanized designs to create the most ideal vertical transportation vehicle for you. It can be widely used in logistics centers, industrial transportation, large parking lots, automobile 4S stores and other places.

### Standard car

Ceiling	Spray painted steel plate
Lighting	Energy saving fluorescent lamp
Car Wall/Car Door	Spray painted steel plate
Control box panel	Hairline stainless steel panel
Floor	Patterned steel plate
Sill	Steel sill
Anti-collision strip	Optional

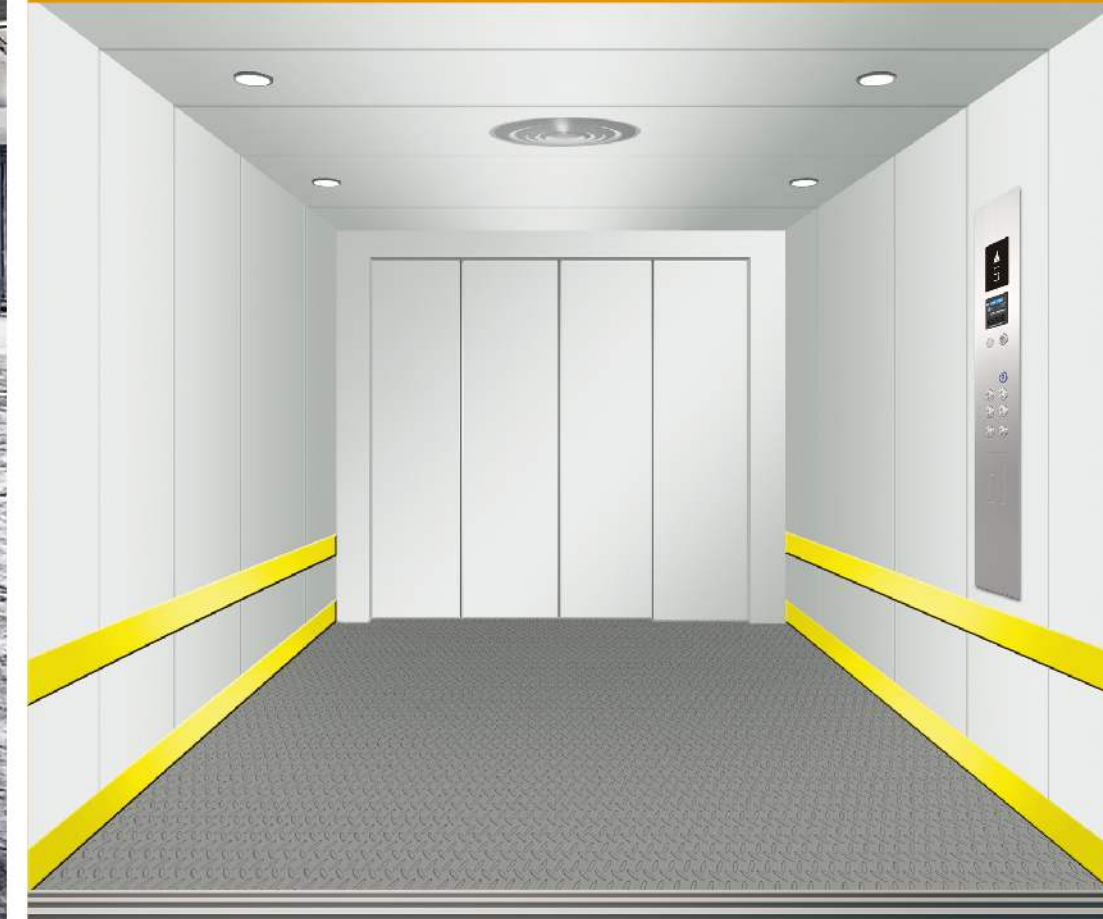

### Easy operation

A dual operation button box is installed inside the elevator car, allowing the driver to easily operate the elevator without leaving the car.

### Convenient access

The front and rear through doors are equipped with a vehicle access control signal management system, making it more convenient for your car to enter and exit.

### Safe and reliable

The ground inside the car is equipped with safety guidance devices to ensure the safety of the elevator and the car.

### Sturdy and durable

High quality steel combined with high-strength and ultra strong structural design ensures that the car will not deform during long-term use.

# Function table

## Standard function

Collective selective control	Upper and lower layer crossing and upper and lower limit protection devices
Variable frequency drive	Downward overspeed protection
Door machine frequency conversion drive	Upward overspeed protection device
Reopen the door on this floor	Light curtain protection
Stop the elevator and open the door	Emergency lighting
Automatic return to base station function	Five party communication device
Straight ahead	Alarm bell
Automatic non-stop passage	Firefighting return
Repeated opening and closing of elevator doors	Micro motion command buttons inside the car and at the landing station
Overloaded elevator stop	Interior floor and direction indicator of the sedan
Prevent stall internal counter protection	Floor by floor, direction indication
Activate protection control	Car fan, automatic lighting switch
Inspection operation	Remote shutdown
Power on and level again	Car accidental movement protection

## Optional function

Station operation control	Auxiliary operation panel operation
Firefighter operation	Front and rear door operation

# Car elevator construction parameters

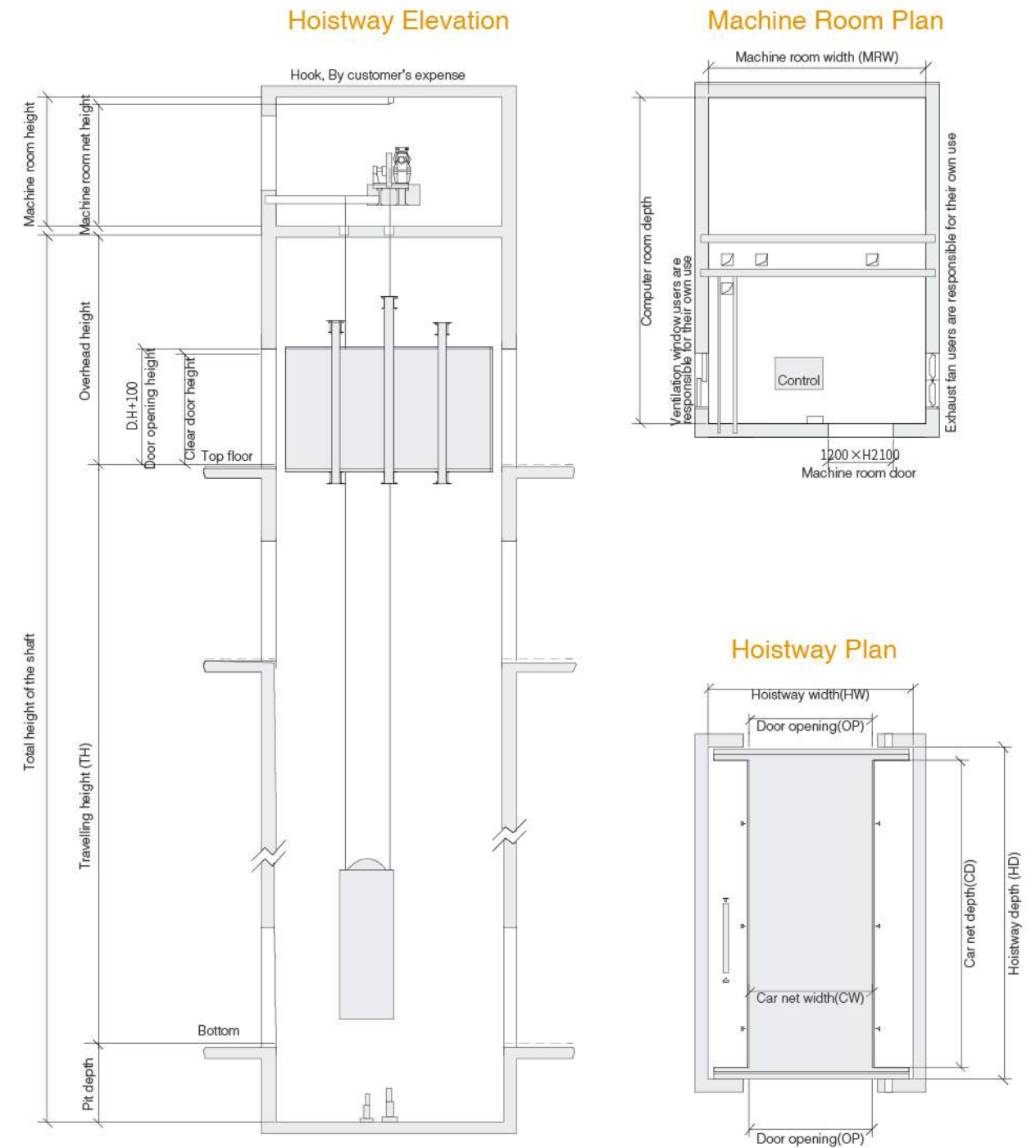

Note: The car elevator is only for use in foreign projects. If domestic projects require the use of cars, please choose a large tonnage cargo elevator.

# Livestock elevator Stable and durable



## Car drainage design

A drain is installed at the rear of the elevator car floor, with a storage tank below to temporarily collect wastewater. The tank has a drainage hole at the end, connected to a stainless steel sewage pipe via an electric solenoid valve. The solenoid valve is controlled by a switch inside the car, allowing the drainage hole to open with a press.

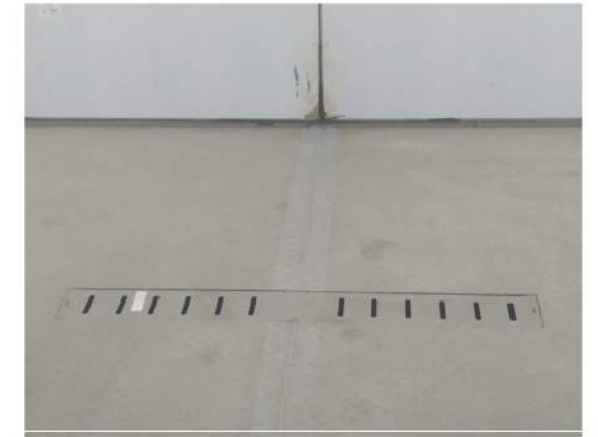

## Anti-trap and leak-proof design at the entrance and exit

A retractable hinged panel is installed at the elevator door, hinged to the car floor. This prevents piglets from stepping into the gap between the threshold and also stops pig waste from falling into the pit and shaft.



## Disinfection and sterilization function

A dedicated disinfection and sterilization device that effectively eliminates bacteria, prevents bacterial growth, and ensures the health of livestock.



## Cabin impact protection design

The car wall is equipped with anti-collision guardrails made of stainless steel square tubes, which are firmly connected to the car bottom to prevent pigs from hitting the car wall damaging the wall panels. A protective barrier is also placed in front of the elevator door for additional protection.



# Machine room livestock elevator construction parameters

# Machine roomless livestock elevator construction parameter

Hoistway Elevation

Machine Room Opening Plan

Machine Room Plan

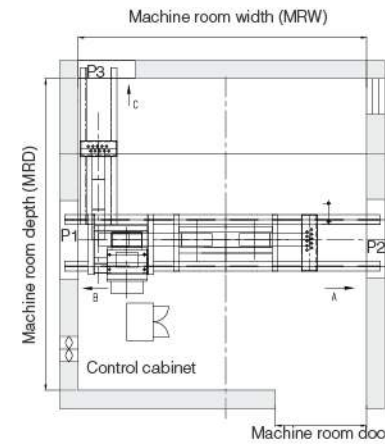
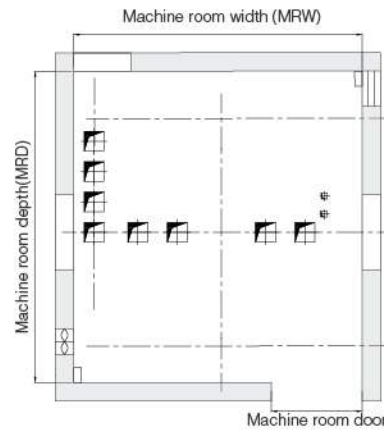
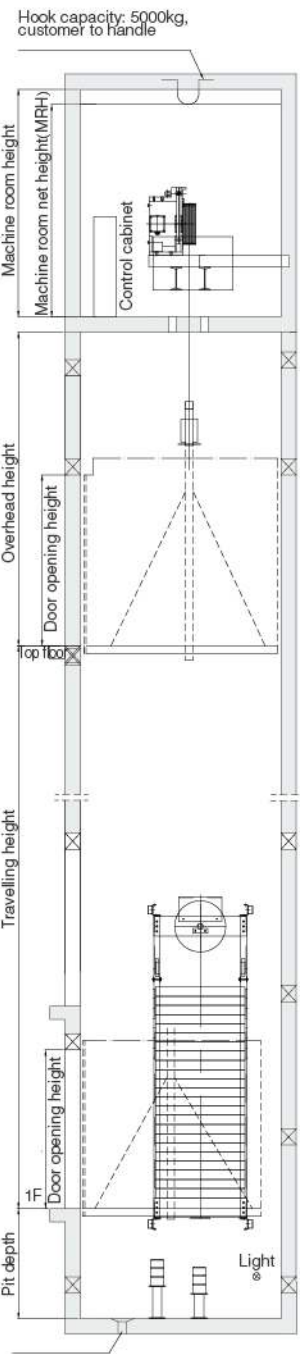

Hoistway Plan

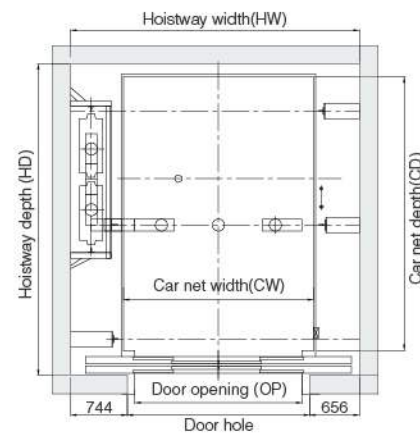

Sump drain connected to the collecting pit (customer to handle both)

Rated load (Kg)	Shaft size (mm)	Car size (mm)	Door opening size (mm)	Rated speed (m/s)	Top level high (mm)	Pit depth (mm)
	(W)x(D)	(W)x(D)x(H)	(W)x(H)			
5000	3800x4100	2400x3600x2500	Central opening ( four panels)	0.5	4600	1800

Hoistway Elevation

Hoistway Beam Plan

Hoistway Beam Opening Elevation

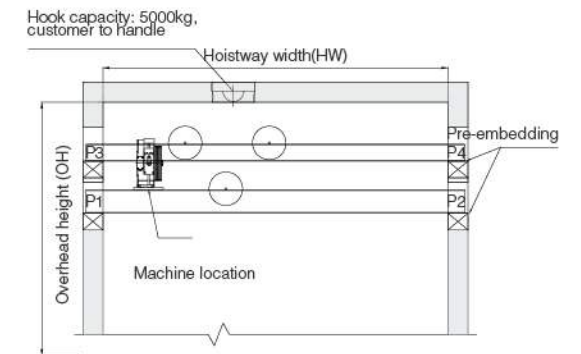
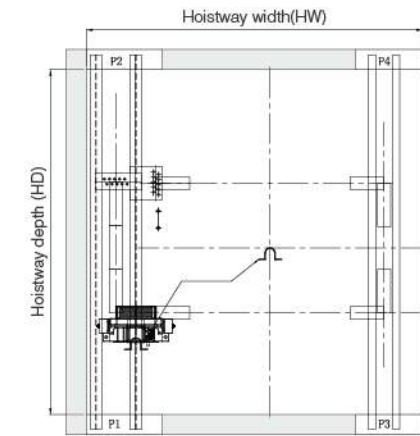
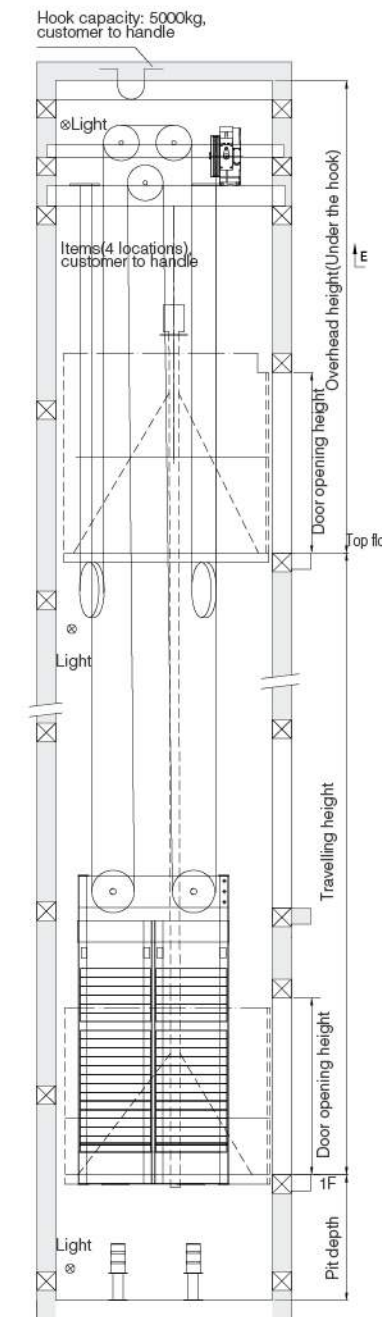

Hoistway Plan

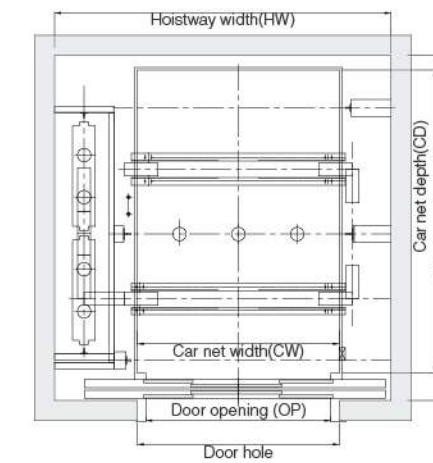

Machine Room Plan

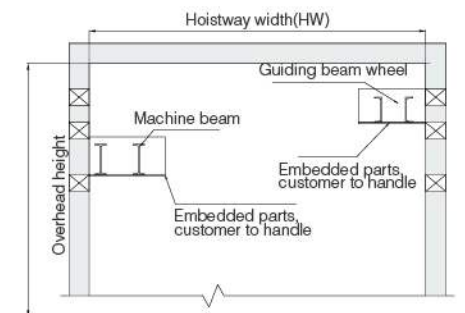

Rated load (Kg)	Shaft size (mm)	Car size (mm)	Door opening size (mm)	Rated speed (m/s)	Top level high (mm)	Pit depth (mm)
	(W)x(D)	(W)x(D)x(H)	(W)x(H)			
5000	4000x4100	2400x3600x2500	Central opening ( four panels)	0.5	5000	1900

Service lift/elevator  
Small space, Great use



Flexible installation:

No machine room, small space, flexible installation location, can be installed with or without a shaft.

Economical and practical:

Low one-time investment cost, can be relocated multiple times for repeated installation and use.

Mature technology:

Adopting industrial grade PLC computer control, data processing is precise and fast, the car moves smoothly, and leveling is accurate.

Complete specifications:

There are various specifications to choose from, including standard, tabletop, window, and floor standing, with different door opening methods, suitable for various occasions.

The miscellaneous elevator is the smallest member of the freight elevator family, which can be installed in inconspicuous corners of buildings to efficiently and quickly transport various necessities for people. Shandong FUJIZY miscellaneous elevator is widely used in places such as hotels, banks, hospitals, libraries, laboratories, and postal departments due to its exquisite, practical, easy to install and maintain characteristics.



Table type  
Used in conjunction with the production line



Floor standing type  
Vertical division



Window type  
Vertical division

